

HOME FLOORING COLLECTION

Vinylcomfort



Nature at your feet

WICANDERS®



Excellence in flooring



Amorim Revestimentos, a company of the Portuguese Amorim Group, with over 130 years of experience in selected cork products, has developed unique flooring and wall covering solutions throughout its history. Amorim Revestimentos sells its products in more than 51 countries and is known throughout the world as a pioneer in creating top-quality, ground-breaking solutions.

Reflecting a highly sustainable development, the Amorim Group developed a revolutionary process that is adapted to nature's rhythms. The first extraction of cork from the cork oak tree occurs only twenty-five years after planting, following which it is harvested in nine-year cycles, without ever damaging the tree in any way. This method allows the cork oak forest – montado - to fulfil its role of fixing CO₂, thus actively contributing to reduce global warming.

The regular extraction of cork is also a decisive contributor to sustainability: environmental (conserving biodiversity and preventing desertification), social (population settlement and jobs creation) and economic. The company's in-depth knowledge and respect for nature, its continuous investment in technological innovation and highly-specialised staff, have guaranteed its leading position in the international field. **Wicanders** has strengthened its existing cork products (**Cork**comfort) and wood-on-cork products (**Wood**comfort), by investing in new product lines such as vinyl (**Vinyl**comfort), linoleum (**Lino**comfort), and parquet (**Parquet**), towards a new phase marked by the evolution from a cork manufacturer to a flooring solutions company.

Cutting-edge technology, know-how, creativity and audacity are merged into an avant-garde approach inspired on nature's values.



Cherry
Palisander

Amber Cherry



Setting **new standards** for flooring

As a result of advanced technological research, this new flooring for public and private areas has changed the way we envision spaces, suggesting a more liberating and inspiring experience. Following the latest trends in flooring, **Vinylcomfort** is a new concept in Luxury Vinyl Tile (LVT) floating floors, surpassing existing glue-down floor solutions and other similar surfaces. Positioned as a forerunner in the vanguard of vinyl flooring for residential and commercial environments, **Vinylcomfort** combines a strong design element with the benefits of an innovative structure supported by a double cork layer. The new **Vinylcomfort** collection has revolutionized the range of avant-garde flooring solutions by perfectly interpreting the textures and patterns of noble hardwoods, exotic stones and innovative materials, offering numerous choices in the creation of comfortable and distinctive atmospheres, achieving a perfect match between sustainability and breakthrough solutions.



A new era for vinyl flooring

With solid technological know-how in developing cork-based flooring, **Wicanders** has innovated in the vinyl flooring market, presenting a pioneering product for home and commercial spaces.

Thanks to its unique characteristics, **Vinylcomfort** distinguishes from traditional glue-down LVT floors by presenting itself in a floating solution, being also superior to other existing vinyl floating solutions, due to a more advanced structure that incorporates an additional cork layer. The natural characteristics of cork provide greater walking comfort, as well as improved acoustic properties. The double cork layer also plays a fundamental role in providing heat insulation, offering you unrivalled comfort with reduced energy costs, improving eco-efficiency.

Vinylcomfort's excellence is enhanced by the nobility of its visuals. Advanced techniques allowed the beauty and texture of various materials to be re-invented, resulting in a stylish collection. Furthermore, innovative features and dimensions, not available in similar competitor products, enriched even more this collection.

The advantages of this product are not limited to aesthetics, also inviting you to enjoy your time. Providing you with a fast and easy installation, it doesn't require a complex subfloor preparation or the use of adhesives that represent increased costs, time consumption and environmental harm.

From production to installation, **Vinylcomfort** stands out for its exceptional design and excellent performance.

Developed for homes, hotels, shops, offices and other locations where fashion, durability and cleanliness of the floor are decisive factors, this line exceeds all the expectations of interior designers, architects and builders. Surprising ambiances can be created at reasonable cost and within a short period of time. After installation, **Vinylcomfort** confirms its efficiency, ensuring many years of easy maintenance and proven resistance to wear and tear.



Palisander

Chalk Oak

Provence
Oak



Explore our essence



Your design for life

FEEL NATURAL

Natural and realistic effects

The matte surface, combined with a wide range of patterns, allows a true material interpretation with effects capable of inspiring unique sensations. The wood visual panels present a more realistic parquet flooring format.

FEEL UNIQUE

Endless options

Architects and interior designers now have at their disposal a unique collection inspired by nature. Following the latest trends on diverse surfaces as wood, concrete, ceramics, aged metal or natural stone, **Vinylcomfort** exhibits genuine textures felt through a simple look. Create sophisticated or rustic ambiances in new or renovated spaces.

FEEL SAFE

A long-lasting surface

Extremely resistant to intense everyday wear and tear, **Vinylcomfort** is your floor for life, at home, shop or office.



Your wellbeing

FEEL RELAXED

Quiet environments

It is a well known fact that noise contributes to stress. Composed by a double cork layer, **Vinylcomfort** offers remarkable sound reduction, promoting a harmonious and relaxing environment.

FEEL WARM

Welcoming environments

The natural properties of cork play a fundamental role in providing heat insulation, offering you unrivalled comfort and hospitality with reduced energy costs. A benefit not only to your investment, but to your health as well.

FEEL COMFORTABLE

Comfort that walks alongside you

Vinylcomfort was designed to provide comfort in the most demanding environments. The double cork layer is soft enough to reduce the impact on your joints and back, allowing you to enjoy natural comfort in the simple act of walking.





European Oak

Bianco Travertine

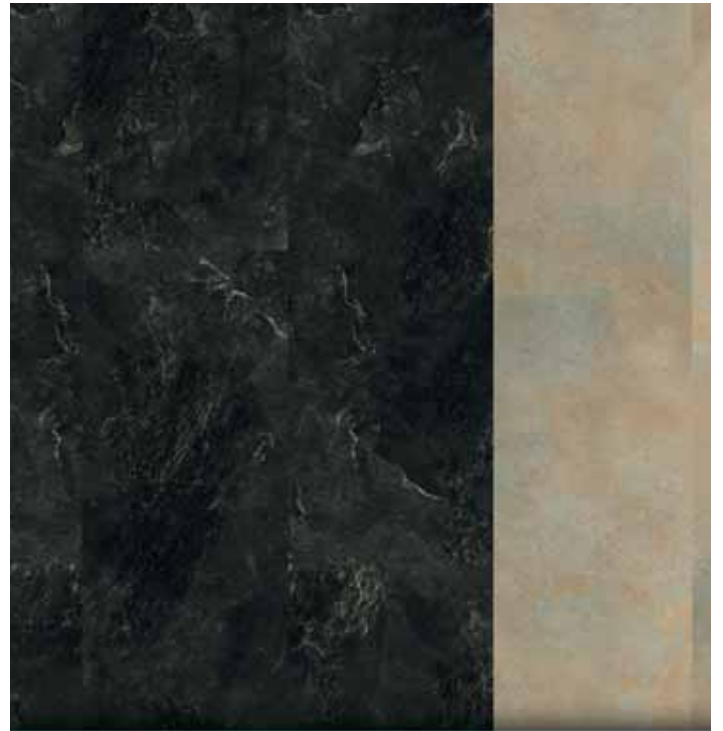

Coal Slate

Volcanic Ash

Your time

FEEL POWERFUL

We create, you live

Vinylcomfort saves you time and money. Quick and easy to install, with the CORKLOC® system you are able to transform your environment without interfering with your day-to-day activities, and also profit from its re-use, if you wish to.

Commercial spaces can benefit from a complete overnight transformation with no need to close. It does not require adhesives or complex subfloor preparation. Furthermore, this product comes with an all around edge sealing for increased moisture protection.

FEEL FREE

Extra time in your day

Thanks to its easy maintenance, **Vinylcomfort** does not require any special care, providing you with the time and freedom to do what you really like. With a sophisticated look, high performance and durability, this is the floor that invites you to enjoy life.



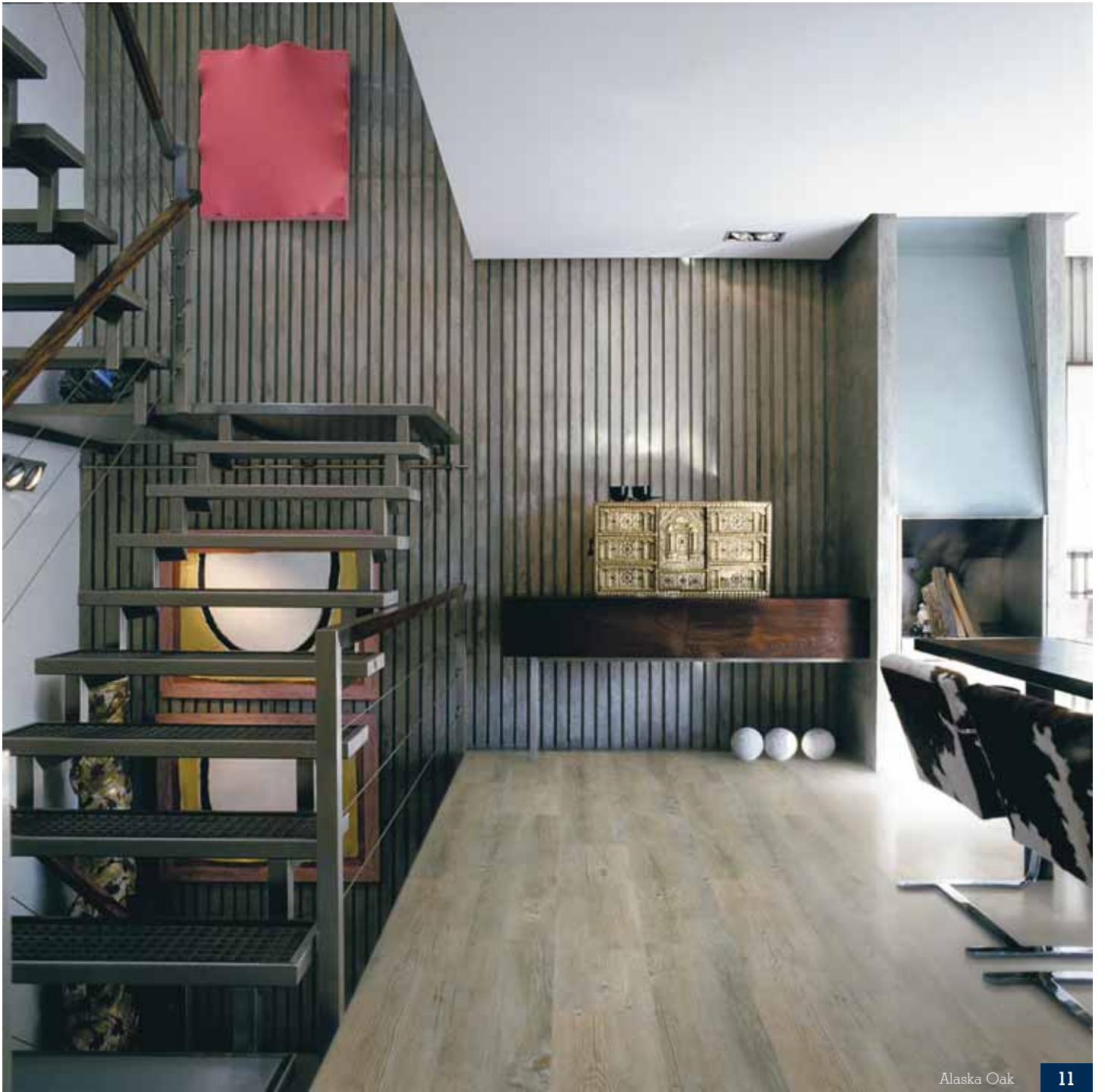

Vinylcomfort visuals



Alaska Oak



Chalk Oak



European Oak



Provence Oak



Canyon Oak



Smoked Oak

Vinylcomfort visuals



Amber Cherry



Cherry



American Walnut



Palisander



Bianco Travertine



Volcanic Ash



Raw Umber



Coal Slate

Product selector

Finishing		PU acrylate UV	PU acrylate UV
Thickness	mm	10,5	10,5
	inches	13/32	13/32
Dimension	mm	905x295	905x185
	Inches	35.5/6x11-10/16	35.5/6x7.9/32
Embossing		Yes	Yes
Bevelling		No	No
Reference			
Raw umber		B0C0001	
Coal Slate		B0C1001	
Bianco Travertine		B0C2001	
Vulcanic Ash		B0C3001	
Alaska Oak			B0C0001
Chalk Oak			B0C1001
European Oak			B0C2001
Provence Oak			B0C3001
Canyon Oak			B0C4001
Smoked Oak			B0C5001
Cherry			B0C6001
Amber Cherry			B0C7001
Palisander			B0C8001
American Walnut			B0C9001

Technical Solutions

FLOATING FLOOR



Home



Commercial

Vinylcomfort

A revolutionary concept

Wicanders presents a cutting-edge product developed to meet your present expectations and future needs!

Atmospheres full of character

Fell your essence in the room you create. See your personality brought to life through 14 unique references with advanced embossing features so that no detail goes unnoticed.

Vinylcomfort will enrich your space with charm and charisma.

Versatility

A floating product combining cork and vinyl, available in two formats conceived for a perfect recreation of the original materials:

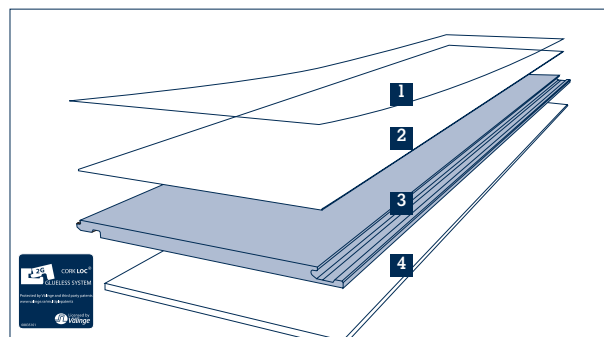

905 x 295 x 10.5 mm – non-wood visuals

905 x 185 x 10.5 mm – wood visuals



- 1.0 Vinyl sheet (with 0,3mm wear layer)
 - 2.0 High density cork core layer
 - 3.0 HDF – High Density Fibreboard with CORKLOC®
 - 4.0 Integrated insulating cork underlay
- All around edge sealing

Technical Data Sheet

Test	Standard	Unit	Vinylcomfort PU acrylate UV
Level of use Domestic	EN 685	Class	23 
Level of use Commercial	EN 685	Class	32 
Level of use Industrial	EN 685	Class	—
General properties	EN 649 + EN 14085		
Dimensions	EN 427	mm	905x295x10,5 905x185x10,5
		Inches	35.5/8x11-10/16x13/32 35.5/8x7-9/32x13/32
Wear layer thickness	EN 429	mm	0,30
Apparent density	EN 672	Kg/m ³	900
Mass per unit area	EN 430	g/m ²	9800
Dimension stability	EN 434	%	Length: 0 Width: 0,05
Flatness (concave)	EN 434	mm	Initial: 0,5 After temperature influence: 0,5
Safety properties			
Fire resistance	EN13501-1	Class	Bfls1
Slip classification	EN 14041	Class	DS
Sliding coefficient	EN 13893	Coeff.	0,41
	DIN 51130	Class	R-9
Additional properties			
Impact sound reduction	ISO 140-8	dB	16
Step sound	NF S 31 - 074	dB	81
Thermal resistance	EN 12667	m ² K/W	0,112
Thermal conductivity	EN 12667	W/mK	0,103
Wear resistance	EN 660-2	Nr. of rev./mass loss	2000 / 138,3 mgr.
Castor chair test	EN 425	Effect	no visible change / damages
Chair leg resistance	EN 424	Effect	no visible change / damages
Residual indentation	EN 433	mm	0,27

(a) The following products were tested: disinfectant, petroleum, spirit, C₂H₅OH, NH₄OH, citric acid, iodine

(b) 1 is the worst, 5 is the best

Test	Standard	Unit	Vinylcomfort PU acrylate UV
Electrostatic propensity	EN 1815	kV	PE foil: PVC: 2,5 - Rubber: 2,1
			None: PVC: 2,0 - Rubber: 1,6
Electrical resistance	EN 1081	Ohm	Vertical: PE foil: 3x10 ¹⁰ none: 3x10 ¹⁰
			Horizontal: PE foil: 2x10 ¹¹ 1x10 ¹¹
Effect of stains	EN 423	Effect (a)	unchanged
Resistance to cigarette burns	EN 1399	Burning	Grade 1 to 3 (b)
		Stubbed	Grade 2 to 4 (b)
Colour fastness	EN 15187	Blue wool scale	>6
Formaldehyde emission	DIN EN 717-1/2	mg/m ³	< 0,01
		Class	E1
PCP (pentachlorophenol)	CEN/TR 14823 (incl-W 409)	mg/Kg	0,1 (PCP free)
VOC loss	EN 664	%	2,1
Exudation of plasticisers	EN 665	Visual assessment	No staining



AMORIM

Excellence in flooring



GB Amorim Flooring UK, +44 1 403 710 001.....info.ar.uk@amorim.com
NL/BE/LU Amorim Benelux B.V., +31 166 604 111.....info.ar.nl@amorim.com
DE Amorim Deutschland GmbH, +49 4221 59 301.....germany.ar.de@amorim.com
AT Amorim Flooring Austria, +43 1 545 16 51 0.....austria.ar.de@amorim.com
CH Amorim Flooring (Switzerland) AG, +41 41 726 20 20.....switzerland.ar.ch@amorim.com
FR Amorim Flooring France No Azur, 0810 811 178info.ar.fr@amorim.com
PT/ES Amorim Revestimentos S.A., +351 22 747 5600.....geral.ar@amorim.com
CN Amorim Revestimentos - Beijing, +86 10 58672159.....amorimre@macau.ctm.net
JP Amorim Japan Corporation, +81 3 5216 3735.....otoiawase-ar@amorim.co.jp
DK/FI/NO/SE Amorim Flooring Nordic A/S, +45 44 681 900.....mail@amorim-flooring.dk
PL Dom Korkowy, Sp. z o.o., +48 12 637 9639.....krakow@domkorkowy.pl
US/CA Amorim Flooring North America, +1 410 553 6062.....info@amorimna.com
Others Amorim Revestimentos, S.A., +351 22 747 5600.....geral.ar@amorim.com

